

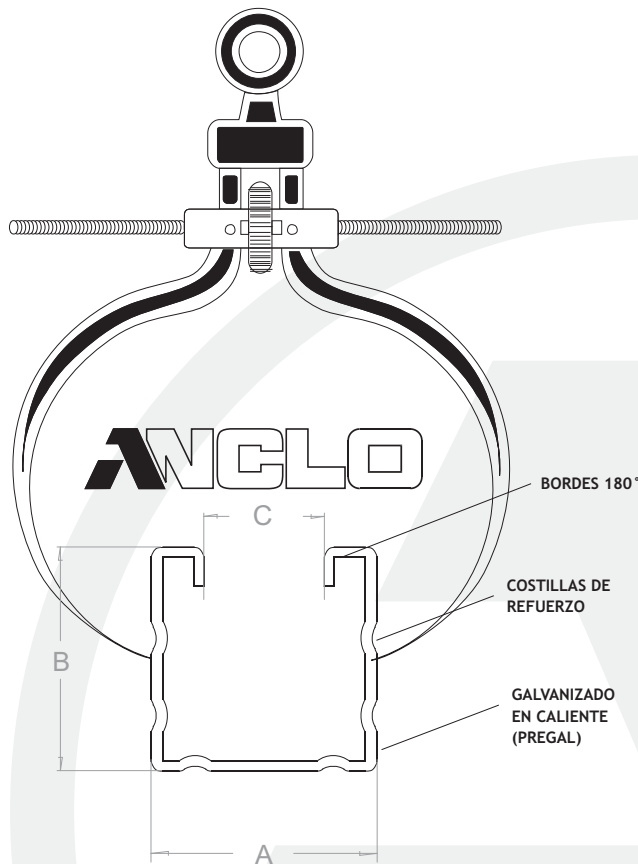

## TODO UN SISTEMA



**1** LOS BORDES a 180° son el secreto del sistema UNICANAL. Estos bordes - a ambos lados y a todo lo largo del lado abierto del UNICANAL - no sólo son la clave de la extraordinaria resistencia de los UNICANALES, sino que también son necesarios para el correcto acoplamiento de abrazaderas y tuercas UNICANAL.

**2** LAS COSTILLAS DE REFUERZO formadas a todo lo largo de los UNICANALES pared delgada y pared gruesa, al igual que los bordes 180° son posibles gracias al exclusivo sistema de plegado gradual y continuo a alta velocidad característico del proceso de perfilado empleado en nuestra planta de Monterrey para fabricar la UNICANAL.

El sistema de perfilado en frío, sin golpes, evita maltratar las estructuras moleculares del acero, incrementando notablemente la capacidad de carga de los UNICANALES.

**3** Los UNICANALES se fabrican en acero de primera ASTM-A 446 grado A PREGALVANIZADO EN CALIENTE en forma continua de conformidad con la norma ASTM-A 525 G60.

**4** El MAYOR ESPESOR DE ZINC depositado en el acero pregalvanizado en caliente permite la protección de bordes y cortes mediante el proceso de protección catódica al actuar el zinc como ánodo de sacrificio y proteger así los bordes expuestos del acero que resultan al cortar los UNICANALES para su uso.

Este proceso de protección no se da con el menor espesor de zinc depositado mediante galvanizado electrolítico.

**3 VECES MÁS PROTECCIÓN ANTICORROSI VA**

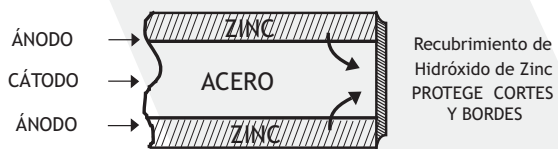

## ESTRUCTURAS

Las estructuras atornilladas UNICANAL:

- \* Se fabrican utilizando perfiles, herrajes, tuercas de resortes y tornillos estandar.
- \* No se requieren herramientas eléctricas ni personal especializado.
- \* Fáciles de adaptar a cualquier espacio o aplicación.
- \* Instalación rápida y limpia, no requiere soldadura, enderezado, esmerilado ni pintura.

## INSTALACIONES

El montaje sobre UNICANAL:

- \* Ahorra tiempo y trabajo en la instalación de conduit, ductos, charolas, gabinetes, etc.
- \* Facilita la alineación para una apariencia profesional.
- \* Protege la instalación de óxido y acumulación de polvo.
- \* Facilita modificaciones posteriores.
- \* Evita la necesidad de soldado o taladrado en obra.

## SERIE REFORZADA / C.40

Uso Industrial



- \* Recomendado para instalar tubería o conduit C.40, en aplicaciones industriales críticas sujetas a altas temperaturas, corrosión o claros largos. Utilizar abrazaderas serie AU.

### PUNTA ROJA

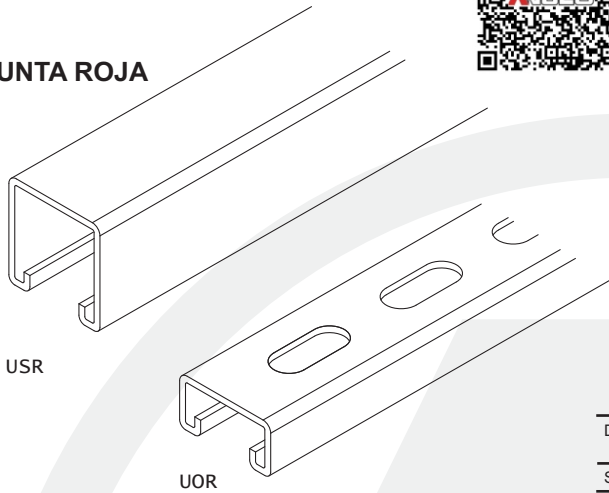

USR

UOR

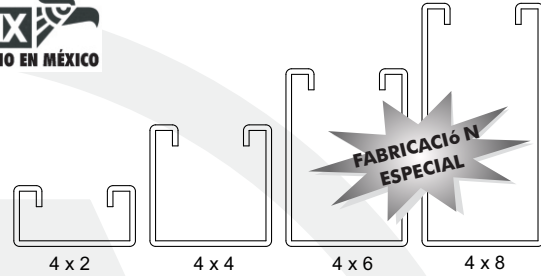

#### ACABADOS DISPONIBLES

- PG: Pregalvanizado en caliente estándar.
- GC: Galvanizado en caliente después de fabricado.
- GP: Poliester epoxy sobre galvanizado Galvaneal.
- Al: Acero inoxidable A 304.

Descripción	Espesor Material	Dimensiones			Peso x metro	Clave Perdido
		A	B	C		
<b>Sólido</b>						
4 x 2	2.5 mm (C.12)	41.3 mm	20.6 mm	22 mm	1.7 kg	USR 4 x 2
4 x 4		41.3 mm	41.3 mm	22 mm	2.5 kg	USR 4 x 4
4 x 6	2.5 mm (C.12)	41.3 mm	62.0 mm	22 mm	3.2 kg	USR 4 x 6
4 x 8		41.3 mm	82.5 mm	22 mm	3.9 kg	USR 4 x 8
<b>Perforado</b>						
4 x 2	2.5 mm (C.12)	41.3 mm	20.6 mm	22 mm	1.6 kg	UOR 4 x 2
4 x 4		41.3 mm	41.3 mm	22 mm	2.4 kg	UOR 4 x 4
4 x 6	2.5 mm (C.12)	41.3 mm	62.0 mm	22 mm	3.0 kg	UOR 4 x 6
4 x 8		41.3 mm	82.5 mm	22 mm	3.8 kg	UOR 4 x 8

## SERIE DOBLE RANURA

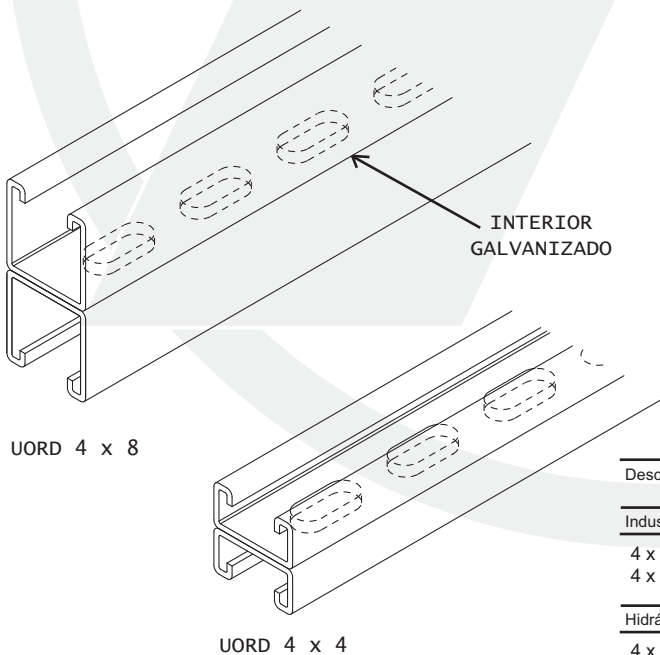

UORD 4 x 8

UORD 4 x 4

- \* Dos rieles pregalvanizados estándar unidos en la base mediante soldadura por resistencia cada 5 cm ofrecen mayor versatilidad en la instalación al contar con ranuras por ambos lados.
- \* Puntos cada 10 cm.

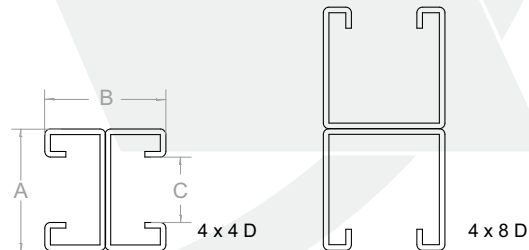

Descripción	Espesor Material	Dimensiones			Peso x metro	Clave Perdido
		A	B	C		
<b>Industrial</b>						
4 x 4	2.5 mm (C.12)	41.3 mm	41.3 mm	22 mm	3.4 kg	UDR 4 x 4
4 x 8	2.5 mm (C.12)	41.3 mm	82.5 mm	22 mm	5.0 kg	UDR 4 x 8
<b>Hidráulico</b>						
4 x 4	1.9 mm (C.14)	41.3 mm	41.3 mm	22 mm	2.5 kg	UDC 4 x 4
4 x 8	1.9 mm (C.14)	41.3 mm	82.5 mm	22 mm	3.6 kg	UDC 4 x 8
<b>Eléctrico</b>						
4 x 4	1.2 mm (C.18)	41.3 mm	41.3 mm	22 mm	1.8 kg	UDE 4 x 4
4 x 8	1.5 mm (C.16)	41.3 mm	82.5 mm	22 mm	3.0 kg	UDE 4 x 8





## SERIE ELÉCTRICA - PARED DELGADA

Acero Pregelvanizado

### PUNTA VERDE

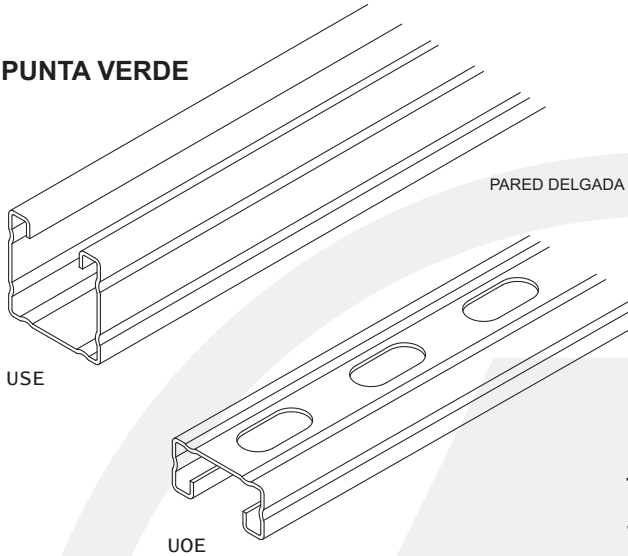

USE

UOE



- \* Nueva versión del clásico perfil unicanal en material más delgado con COSTILLAS DE REFUERZO FORMADAS A TODO LO LARGO DEL RIEL para mayor resistencia.
- \* Para instalaciones con conduit pared delgada (C.20) o pared gruesa (C.30 intermedio) utilizando económicas abrazaderas serie AW o AE.
- \* Ideal para usarse en tramos cortos comúnmente usados como soportes para líneas de conduit pared delgada o charolas portacables.

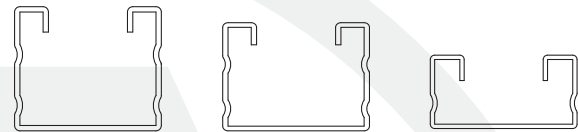

4 x 4

4 x 4 C

4 x 2

Descripción	Espesor Material	Dimensiones			Peso x metro	Clave Perdido
		A	B	C		
<b>Sólido</b>						
4 x 2	1.2 mm (C.18)	41.3 mm	20.6 mm	22 mm	0.9 kg	USE 4 x 2
4 x 4 C	1.2 mm (C.18)	41.3 mm	35.0 mm	22 mm	1.0 kg	USE 4 x 4 C
4 x 4	1.5 mm (C.16)	41.3 mm	41.3 mm	22 mm	1.5 kg	USE 4 x 4
<b>Perforado</b>						
4 x 2	1.2 mm (C.18)	41.3 mm	20.6 mm	22 mm	0.8 kg	UOE 4 x 2
4 x 4 C	1.2 mm (C.18)	41.3 mm	35.0 mm	22 mm	0.9 kg	UOE 4 x 4 C
4 x 4	1.5 mm (C.16)	41.3 mm	41.3 mm	22 mm	1.4 kg	UOE 4 x 4

## SERIE HIDRÁULICA - PARED GRUESA

Acero Pregelvanizado

### PUNTA AZUL

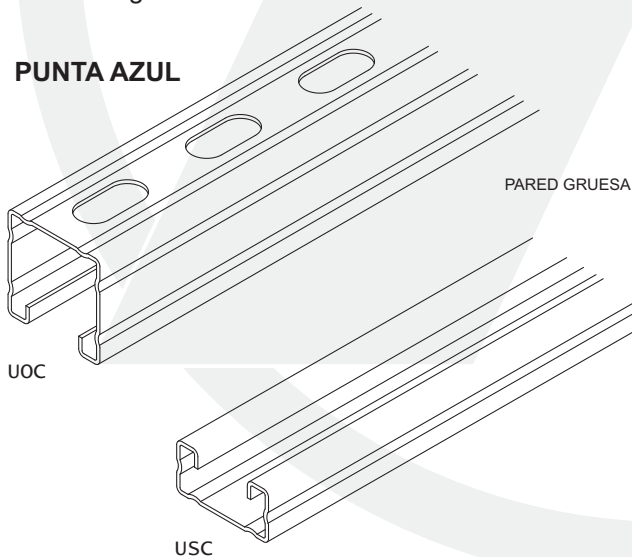

UOC

USC



- \* Ahora con COSTILLAS DE REFUERZO FORMADAS A TODO LO LARGO DEL RIEL para desarrollar al máximo la capacidad del material.
- \* Para instalaciones eléctricas e hidráulicas con tubo cédula 40 o cuando el claro o el número de tubos lo requiere. Para usarse con abrazaderas serie AU cédula.

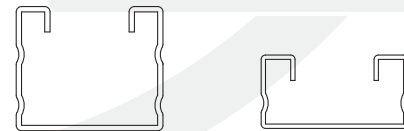

4 x 4

4 x 2

Descripción	Espesor Material	Dimensiones			Peso x metro	Clave Perdido
		A	B	C		
<b>Sólido</b>						
4 x 2	1.5 mm (C.16)	41.3 mm	20.6 mm	22 mm	1.1 kg	USC 4 x 2
4 x 4	1.9 mm (C.14)	41.3 mm	41.3 mm	22 mm	1.8 kg	USC 4 x 4
<b>Perforado</b>						
4 x 2	1.5 mm (C.16)	41.3 mm	20.6 mm	22 mm	1.0 kg	UOC 4 x 2
4 x 4	1.9 mm (C.14)	41.3 mm	41.3 mm	22 mm	1.7 kg	UOC 4 x 4

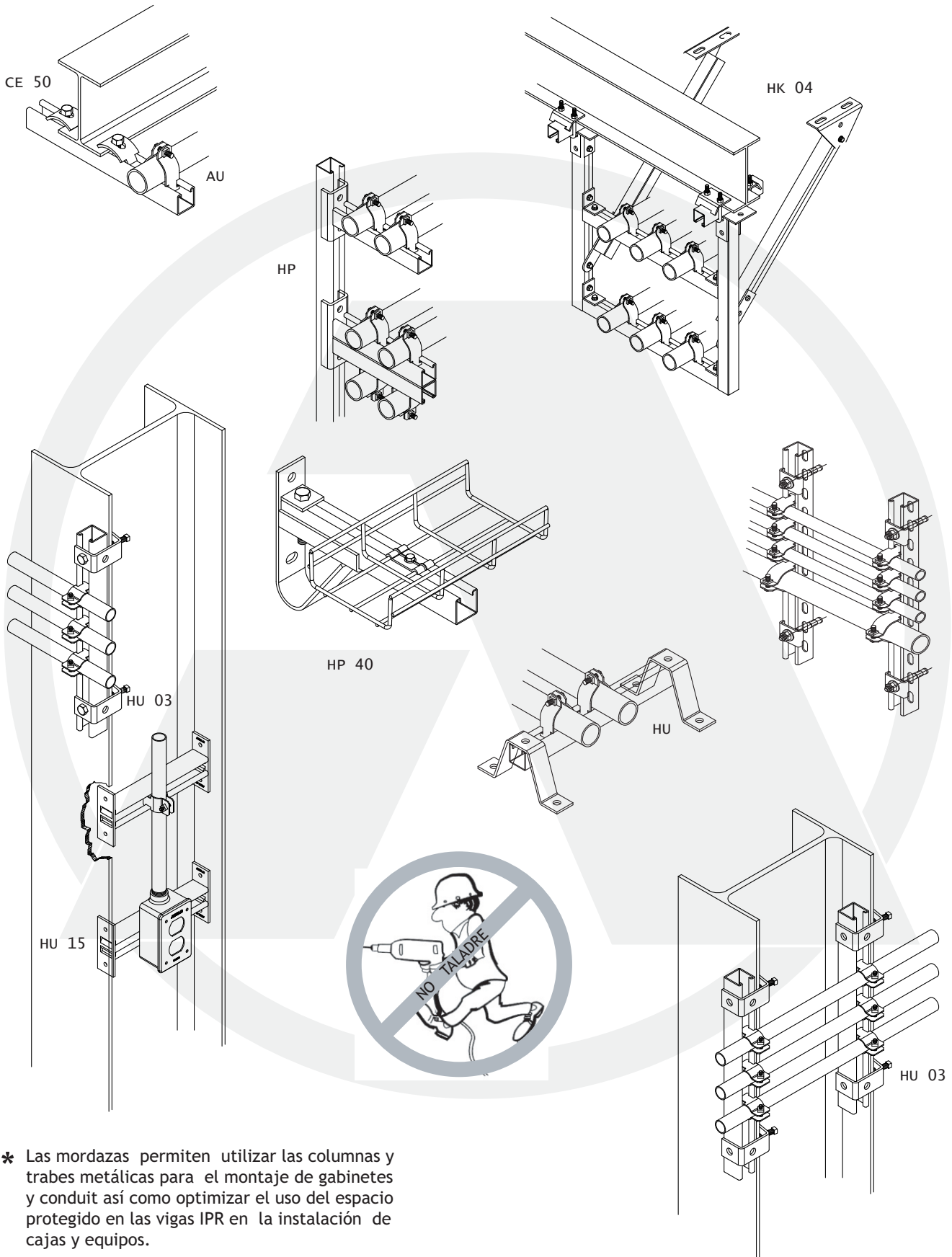

\* Las mordazas permiten utilizar las columnas y traveses metálicas para el montaje de gabinetes y conduit así como optimizar el uso del espacio protegido en las vigas IPR en la instalación de cajas y equipos.

# MONTAJE DE INSTALACIONES

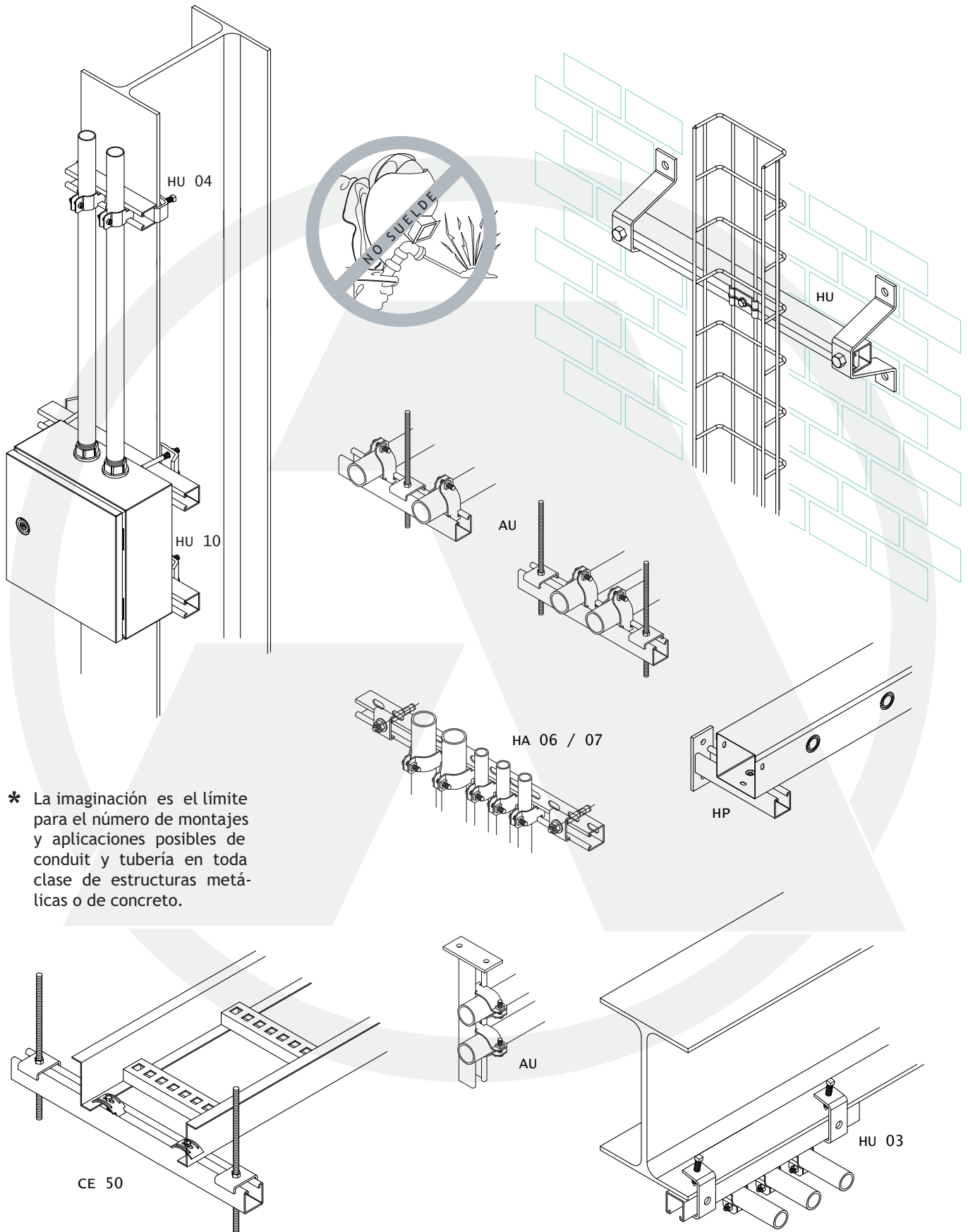

\* La imaginación es el límite para el número de montajes y aplicaciones posibles de conduit y tubería en toda clase de estructuras metálicas o de concreto.



## MORDAZAS TIPO "C"

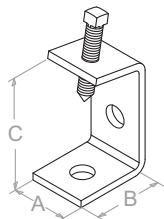

HU 03

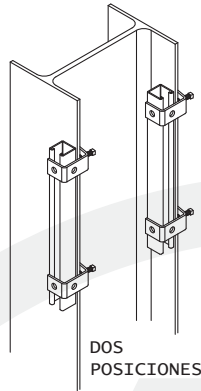

DOS POSICIONES

- \* Usar tuerca de resorte y tornillo para lograr una fijación **SEGURA**

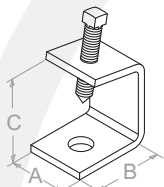
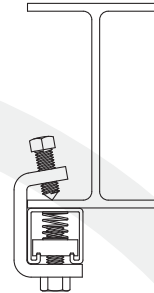

HU 03 C

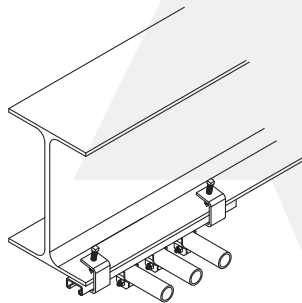

- \* Para fijar UNICANAL a lo largo de elementos estructurales como vigas IPR o ángulos sin necesidad de soldadura ni taladrado.
- \* Puede fijar UNICANALES con la ranura de montaje en dos posiciones a materiales de hasta 2 cm de espesor.
- \* Tuerca de resorte y tornillo para asegurar UNICANALES unicanal deben ordenarse por separado.
- \* Fabricado en material de 4.7 mm con tornillo y tuerca de 9.5 mm premontados. Acabado electro galvanizado estandar blanco no contaminante. Otros acabados sobre pedido.
- \* Tramo UNICANAL no incluido. Se surten en pares.

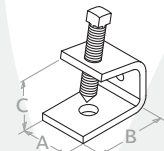

HU 04

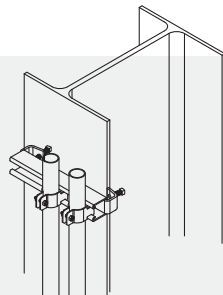

Para Perfil	Carga Posible	Dimensiones mm			Peso Aprox.	Clave Pedido
		A	B	C		
4 x 4	225 kg	38.1	41.3	73	225 gr	HU 03
4 x 2	225 kg	38.1	41.3	50	195 gr	HU 03 C
TODOS	200 kg	31.7	41.3	30	145 gr	HU 04

SE SURTEN EN PARES

## SOPORTE INTERIOR VIGAS

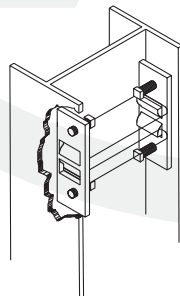
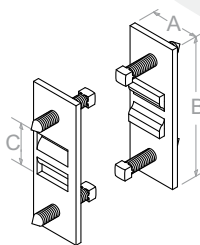

- \* Para fijar UNICANALES de 4 x 4 entre los patines de vigas IPR o similares.
- \* Ideal para fijar conduit y cajas para dispositivo entre los patines de las vigas.
- \* Fabricado en material de 4.7 mm con tornillo y tuerca de 9.5 mm. Acabado electrogalvanizado estandar. Otros acabados sobre pedido.
- \* Tramo UNICANAL no incluido. Se surten en pares.

Para Perfil	Carga Posible	Dimensiones mm			Peso Aprox.	Clave Pedido
		A	B	C		
4 x 4	360 kg	41.3	117.5	35	205 gr	HU 15

SE SURTEN EN PARES



## MORDAZAS TIPO VENTANA

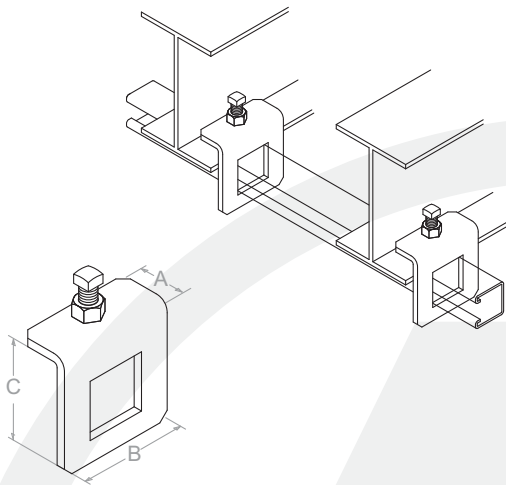

- \* Tradicional diseño de mordaza tipo ventana permite fijar UNICANAL en cualquier posición.
- \* Mordaza en material de 4.7 x 90 mm. Tornillo opresor y contratuercas de 9.5 mm (3 / 8"). Acabado electrogalvanizado.

Para Perfil	Carga Posible	Dimensiones mm			Peso Aprox.	Clave Pedido
		A	B	C		
4 x 4	200 kg	33	89	84	340 gr	HU 14

## ABRAZADERA CUADRADA

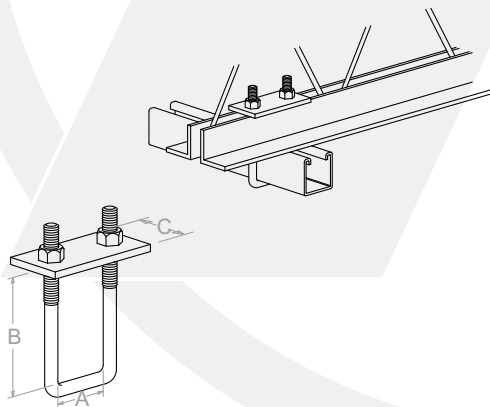

- \* Para fijar unicanal a vigas de alma abierta tipo Joist.
- \* Abrazadera y tuercas de 9.5 mm (3 / 8"). Placa de respaldo de 4.7 x 50 mm. Acabado electrogalvanizado.
- \* Tramo UNICANAL no incluido. Se surten en pares.

Para Perfil	Carga Posible	Dimensiones mm			Peso Aprox.	Clave Pedido
		A	B	C		
4 x 4	450 kg	41.3	79	50	265 gr	HU 26
4 x 8	450 kg	41.3	120	50	295 gr	HU 27

## MORDAZAS TIPO ABRAZADERA

Con garra para viga o polín

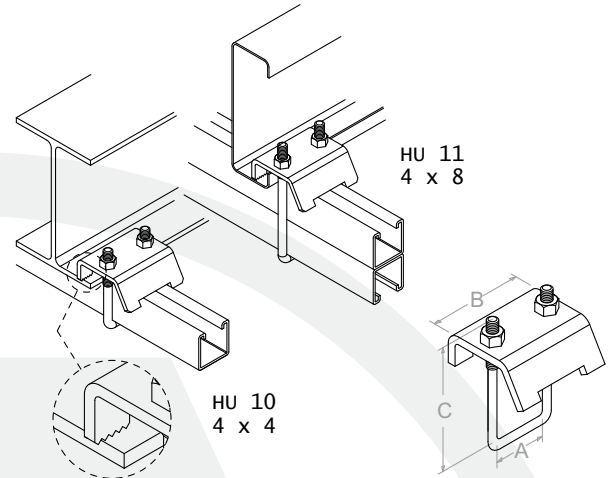

- \* Nuevo diseño con guías centradoras y borde de agarre. Para fijar unicanal a vigas tipo IPR o largueros con borde o vigas. Permite fijar unicanal en cualquier posición.
- \* Abrazadera y tuercas de 9.5 mm (3 / 8"). Acabado electrogalvanizado. Mordaza en material de 4.7 x 76 mm.
- \* Tramo UNICANAL no incluido. Se surten en pares.

Para Perfil	Carga Posible	Dimensiones mm			Peso Aprox.	Clave Pedido
		A	B	C		
4 x 4	450 kg	41.3	76	98	450 gr	HU 10
4 x 8	450 kg	41.3	76	133	480 gr	HU 11

## MORDAZAS TIPO ABRAZADERA

Modelo tradicional para viga

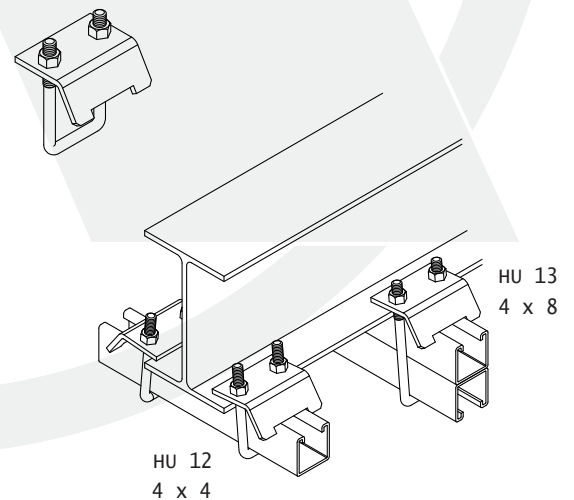

- \* Abrazadera y tuercas de 9.5 mm (3 / 8"). Placa de agarre de 4.7 x 50 mm. Acabado electrogalvanizado.

Para Perfil	Carga Posible	Dimensiones mm			Peso Aprox.	Clave Pedido
		A	B	C		
4 x 4	450 kg	41.3	76	98	400 gr	HU 12
4 x 8	450 kg	41.3	76	133	430 gr	HU 13



## MÉNSULAS BASE PLANA

Para Fijación Directa sobre Muros

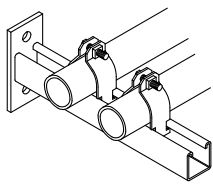

SENCILLA

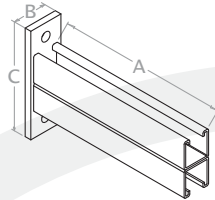

DOBLE

- \* Para anclar a columnas o traves facilitando la instalación compacta de conduit, tubo, ductos o charolas portacables.

Largo A		Carga Uniforme	Peso Aprox.	Clave Pedido
cm	pulg			
<b>Base plana UNICANAL sencilla</b>				
15 cm	6"	854 kg	0.73 kg	HP 02
30 cm	12"	569 kg	1.17 kg	HP 03
<b>Base plana UNICANAL doble</b>				
30 cm	12"	889 kg	2.38 kg	HP 14
45 cm	18"	591 kg	3.27 kg	HP 15
61 cm	24"	445 kg	4.15 kg	HP 16
76 cm	30"	356 kg	5.00 kg	HP 17

## SOPORTES SEPARADORES

Para montar tubo o conduit, charolas o ductos:



- \* Bajo pisos falsos
- \* Sobre muros
- \* En azoteas

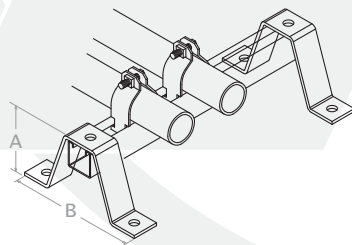

- \* Mantiene separación con la superficie para librar obstáculos y eliminar humedades y acumulación de polvo.

Altura A		Ancho B		Peso Aprox.	Clave Pedido
cm	pulg	cm	pulg		
10 cm	4"	20 cm	8"	0.53 kg	HU 20
15 cm	6"	25 cm	10"	0.71 kg	HU 21
20 cm	8"	30 cm	12"	0.89 kg	HU 22
25 cm	10"	35 cm	14"	1.06 kg	HU 23
30 cm	12"	35 cm	14"	1.21 kg	HU 24
35 cm	14"	35 cm	14"	1.36 kg	HU 25

## MÉNSULAS BASE U

Para Montar sobre Rieles UNICANAL

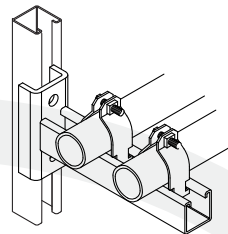

SENCILLA

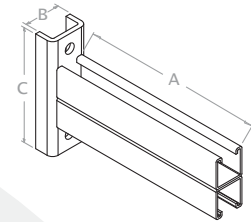

DOBLE

- \* Montajes sobre UNICANALES verticales facilita la alineación y ajustes, acelera la instalación y es ideal para instalaciones multiniveles.

Largo A		Carga Uniforme	Peso Aprox.	Clave Pedido
cm	pulg			
<b>Base U UNICANAL sencilla</b>				
15 cm	6"	854 kg	0.82 kg	HP 05
30 cm	12"	427 kg	1.27 kg	HP 06
45 cm	18"	267 kg	1.71 kg	HP 07
<b>Base U UNICANAL doble</b>				
30 cm	12"	889 kg	2.50 kg	HP 18
45 cm	18"	591 kg	3.39 kg	HP 19
61 cm	24"	445 kg	3.89 kg	HP 20
76 cm	30"	356 kg	4.71 kg	HP 21
90 cm	36"	293 kg	5.63 kg	HP 22

## BASE PARA MÉNSULA

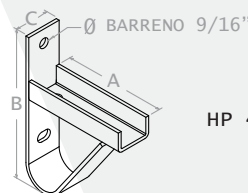

HP 40

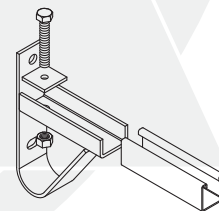

- \* Económicas bases para ménsula, permiten fabricar fácilmente en obra ménsulas a la medida sin necesidad de soldar o taladrar.

- \* Usar con perfiles perforados para evitar taladrado del riel.

- \* Se surten completas con tope de sujeción, tornillo, rondana y dos anclas.

Dimensiones			Peso Aprox.	Clave Pedido
A	B	C		
150 mm	200 mm	50 mm	1.25 kg	HP 40





## ABRAZADERAS CONDUIT - PARED DELGADA

**AW**

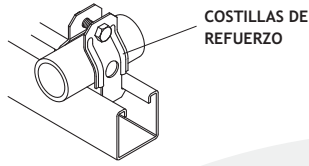

\* Ajuste perfecto con el menor diámetro exterior de los conduit pared delgada C.20. Perforación de identificación evita confusiones.

Tamaño Nominal mm	Tamaño Nominal pulg	Material Espesor	Peso Aprox. 100 Jgos.	Clave Pedido
13	1 / 2"	1.2 mm (C.18)	3.2 kg	AW 12
19	3 / 4"	1.2 mm (C.18)	3.5 kg	AW 34
25	1"	1.5 mm (C.16)	5.3 kg	AW 100
32	1 1 / 4"	1.5 mm (C.16)	7.2 kg	AW 114
38	1 1 / 2"	1.5 mm (C.16)	7.7 kg	AW 112
51	2"	1.5 mm (C.16)	9.0 kg	AW 200
63	2 1 / 2"	1.9 mm (C.14)	17.0 kg	AE 212
76	3"	1.9 mm (C.14)	20.0 kg	AE 300
102	4"	1.9 mm (C.14)	24.0 kg	AE 400

## ABRAZADERAS CONDUIT - PARED GRUESA

**AE**

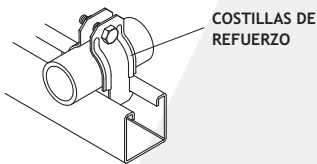

\* Dimensionadas para conduit pared gruesa C.30 o conduit de PVC rígido en instalaciones comerciales.

Tamaño Nominal mm	Tamaño Nominal pulg	Material	Peso Aprox. 100 Jgos.	Clave Pedido
13	1 / 2"	1.2 mm (C.18)	2.7 kg	AE 12
19	3 / 4"	1.2 mm (C.18)	3.0 kg	AE 34
25	1"	1.2 mm (C.18)	3.8 kg	AE 100
32	1 1 / 4"	1.5 mm (C.16)	5.9 kg	AE 114
38	1 1 / 2"	1.5 mm (C.16)	7.1 kg	AE 112
51	2"	1.5 mm (C.16)	7.6 kg	AE 200
63	2 1 / 2"	1.9 mm (C.14)	10.5 kg	AE 212
76	3"	1.9 mm (C.14)	12.4 kg	AE 300
102	4"	1.9 mm (C.14)	15.6 kg	AE 400
152	6"	1.9 mm (C.14)	20.3 kg	AE 600
203	8"	1.9 mm (C.14)	33.6 kg	AE 800
254	10"	1.9 mm (C.14)	37.0 kg	AE 1000
300	12"	1.9 mm (C.14)	52.5 kg	AE 1200
350	14"	1.9 mm (C.14)	55.7 kg	AE 1400
400	16"	1.9 mm (C.14)	62.7 kg	AE 1600

## ABRAZADERAS CONDUIT C.40

**AU**

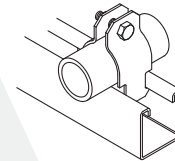

\* Para usarse con conduit o tubo C.40 en instalaciones industriales.

Tamaño Nominal mm	Tamaño Nominal pulg	Material	Peso Aprox. 100 Jgos.	Clave Pedido
13	1 / 2"	1.5 mm (C.16)	3.7 kg	AU 12
19	3 / 4"	1.5 mm (C.16)	5.3 kg	AU 34
25	1"	1.9 mm (C.14)	6.2 kg	AU 100
32	1 1 / 4"	1.9 mm (C.14)	7.4 kg	AU 114
38	1 1 / 2"	1.9 mm (C.14)	8.4 kg	AU 112
51	2"	1.9 mm (C.14)	10.4 kg	AU 200
63	2 1 / 2"	2.5 mm (C.12)	14.4 kg	AU 212
76	3"	2.5 mm (C.12)	18.0 kg	AU 300
102	4"	2.5 mm (C.12)	21.8 kg	AU 400
152	6"	2.5 mm (C.12)	29.0 kg	AG 600
203	8"	2.5 mm (C.12)	48.0 kg	AG 800
254	10"	2.5 mm (C.12)	53.0 kg	AG 1000
300	12"	2.5 mm (C.12)	75.0 kg	AG 1200
350	14"	2.5 mm (C.12)	79.5 kg	AG 1400
400	16"	2.5 mm (C.12)	89.5 kg	AG 1600

## GRAPA CHAROLA

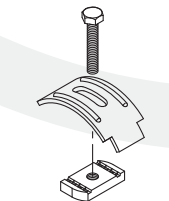
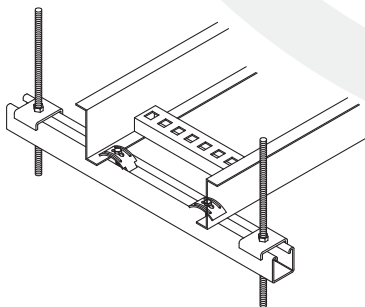

INCLUYE TORNILLO Y TUERCA

Para Perfil	Carga Posible	Material mm	Tornillo mm	Tornillo pulg	Peso Aprox.	Clave Pedido
TODOS	100 kg	1.9 (C.14)	6.5	1 / 4"	52 gr	CE 50

## GRAPA MALLA

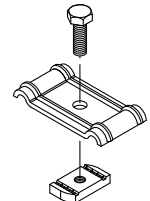
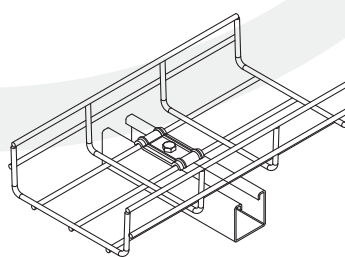

INCLUYE TORNILLO Y TUERCA

Para Perfil	Carga Posible	Material mm	Tornillo mm	Tornillo pulg	Peso Aprox.	Clave Pedido
TODOS	100 kg	1.9 (C.14)	6.5	1 / 4"	48 gr	CE 70



## BARRAS ROSCADAS COMERCIALES

Fierro Comercial (SAE-1008) Acabado Electrolgalvanizado

\* El colgante estandar en todo tipo de instalaciones.

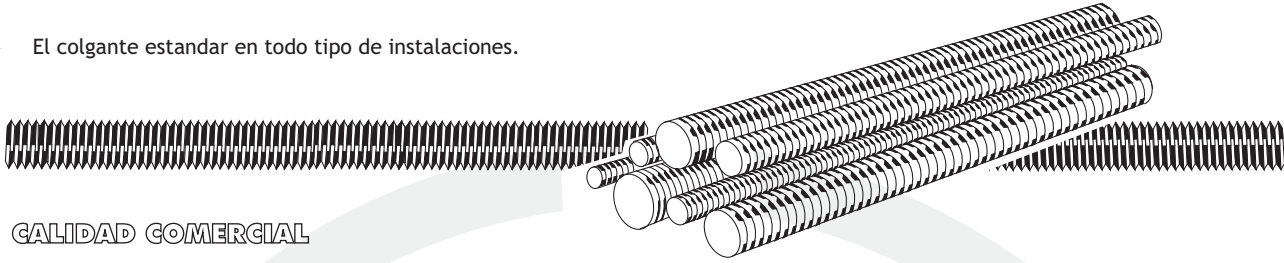

**GALIDAD COMERCIAL**

Tamaño Nominal	Cuerda UNC		Peso x Metro	Carga Posible	Tramos de 1 metro			Tramo de 3 metros		
	Diámetro	Hilo x pulg			Clave Pedido	Piezas x Atado	Peso x Atado	Clave Pedido	Piezas x Atado	Peso x Atado
5 mm	3 / 16"	24	0.10 Kg	50 kg	BR 36 100	50	4.85 Kg	-	-	-
6.4 mm	1 / 4"	20	0.18 Kg	100 Kg	BR 14 100	50	9.10 Kg	BR 14 300	50	27.30 kg
8 mm	5 / 16"	18	0.29 Kg	175 Kg	BR 56 100	25	7.32 Kg	BR 56 300	25	21.98 kg
10 mm	3 / 8"	16	0.42 Kg	275 Kg	BR 38 100	25	10.62 Kg	BR 38 300	25	31.88 kg
11 mm	7 / 16"		0.54 Kg		BR 76 100	20	10.88 Kg	-	-	-
13 mm	1 / 2"	13	0.80 Kg	535 Kg	BR 12 100	20	15.92 Kg	BR 12 300	15	35.82 kg
16 mm	5 / 8"	11	1.25 kg	820 Kg	BR 58 100	15	18.84 kg	BR 58 300	10	37.68 kg
19 mm	3 / 4"	10	1.85 Kg	1225 Kg	BR 34 100	10	18.58 Kg	BR 34 300	5	27.87 kg
22 mm	7 / 8"	9	2.54 Kg	1680 Kg	BR 78 100	10	25.46 Kg	BR 78 300	5	38.19 kg
25 mm	1"	8	3.33 kg	2245 Kg	BR 100 100	5	16.64 kg	BR 100 300	2	19.97 kg

## TUERCAS, RONDANAS Y COPLES

\* Cuerdas UNC 2 A.

\* Acabado galvanizado electrolítico.

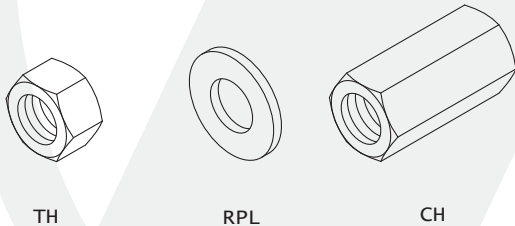

TH

RPL

CH

Nominal		Tuerca Galvanizada	Rondana Galvanizada	Coples Galvanizados
mm	pulg			
6.4 mm	1 / 4"	TH 14	RPL 14	CH 14
8 mm	5 / 16"	TH 56	RPL 56	CH 56
10 mm	3 / 8"	TH 38	RPL 38	CH 38
13 mm	1 / 2"	TH 12	RPL 12	CH 12
16 mm	5 / 8"	TH 58	RPL 58	CH 58
19 mm	3 / 4"	TH 34	RPL 34	CH 34
22 mm	7 / 8"	TH 78	RPL 78	CH 78
25 mm	1"	TH 100	RPL 100	CH 100

## CINTAS PERFORADAS

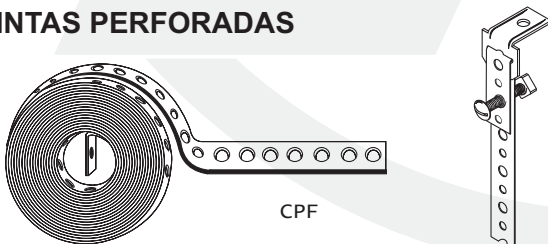

CPF

\* Fabricadas en acero pregalvanizado de 19 x 0.5 mm con perforaciones alternas de 5 y 7 mm para tornillos (3 / 16" y 1 / 4").

\* Ideal para cargas ligeras formando abrazadera sobre conduit o tubo y alrededor de elemento estructural. Se ofrece ángulo para fijar a concreto.

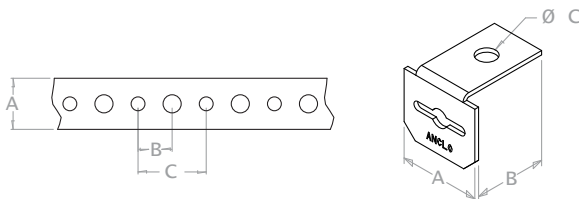

Descripción *	Dimensiones mm			Peso x Rollo	Clave Pedido
	A	B	C		
<b>Cintas Perforadas</b>					
Rollo con 3 metros	19	13	25	0.18 kg	CPF 3
Rollo con 5 metros	19	13	25	0.30 kg	CPF 5
Rollo con 10 metros	19	13	25	0.61 kg	CPF 10
Rollo con 25 metros	19	13	25	1.52 kg	CPF 25
Ángulo de fijación	28	32	7		CPF 100



## MORZADAS DE ACERO

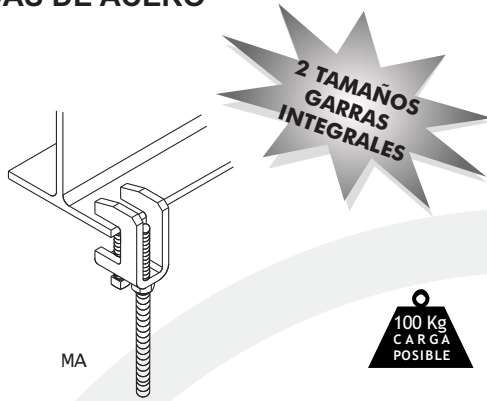

- \* Fabricada en gruesa placa de 4.7 mm de espesor y acabada en galvanizado electrolítico blanco no contaminante.
- \* Las mordazas se surten con opresor endurecido y tuerca de seguridad premontados.

Cuerda		Espesor Agarre		Peso Aprox. por Ciento	Clave Pedido
mm	pulg	mm	pulg		
6.4 mm	1 / 4"	19 mm	3 / 4"	12.9 kg	MA 14 34
10 mm	3 / 8"	19 mm	3 / 4"	12.9 kg	MA 38 34
10 mm	3 / 8"	32 mm	1 1 / 4"	14.2 kg	MA 38 114
13 mm	1 / 2"	32 mm	1 1 / 4"	14.2 kg	MA 12 114

- \* No incluye barra roscada ni tuerca ilustradas.

## SOPORTE FIJABARRAS

Para Fijar a Concreto

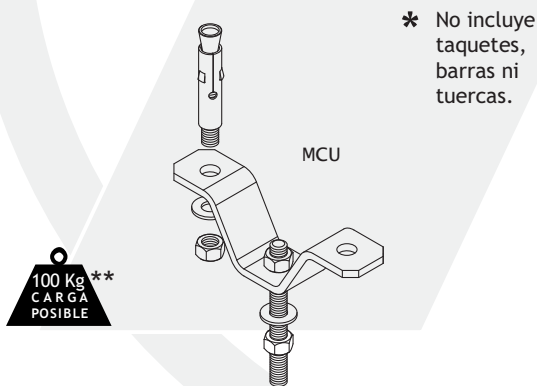

- \* Soporte anclable distribuye la carga entre dos anclajes para máxima seguridad, permite ajuste de altura en la barra roscada.

Para Barra		Tornillos Fijación		Peso Aprox. x Ciento	Clave Pedido
mm	pulg	mm	pulg		
6.4 mm	1 / 4"	6.4 mm	1 / 4"	21.0 kg	MCU 14
10 mm	3 / 8"	10 mm	3 / 8"	20.5 kg	MCU 38
13 mm	1 / 2"	10 mm	3 / 8"	20.0 kg	MCU 12

- \*\* Carga posible al fijar correctamente con anclas de expansión a elementos estructurales de concreto armado.

## MORDAZAS FUNDIDAS

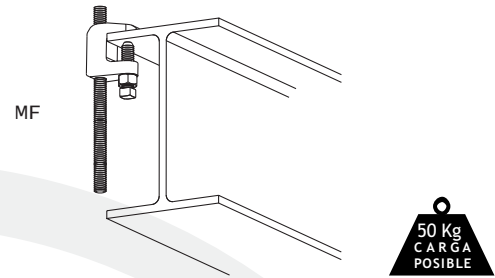

- \* Mordaza de hierro fundida acabada en galvanizado electrolítico.
- \* Se surte con opresor endurecido y tuerca de seguridad premontada.

Cuerda		Espesor Agarre		Peso Aprox. x Ciento	Clave Pedido
mm	pulg	mm	pulg		
6.4 mm	1 / 4"	19 mm	3 / 4"	7.0 kg	MF 14 34
10 mm	3 / 8"	19 mm	3 / 4"	10.6 kg	MF 38 34
10 mm	3 / 8"	32 mm	1 1 / 4"	13.3 kg	MF 38 114
13 mm	1 / 2"	32 mm	1 1 / 4"	12.5 kg	MF 12 114

- \* No incluye barra roscada.

## MORDAZA TIJERA - USO PESADO

Ajustable, articulada

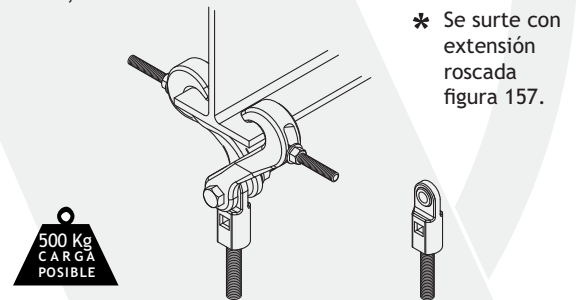

- \* Para vigas con patines inferiores de 6 a 18 cm (2 3/8" a 7") y espesor máximo de 16 mm (5 / 8").
- \* Cumple con normas USA FED SPEC WW-H-17 / E TIPO 30 y MSS SP69 TIPO 30 para soportar tubería de hasta 20 cm (8") de diámetro nominal.
- \* Fabricadas en fundición de hierro nodular de conformidad con las especificaciones de las figuras 218 y 157.

Cuerda		Dimensiones mm		Peso Aprox. x pza.	Clave Pedido
mm	pulg	A	B		
10 mm	3 / 8"	62	14	1.28 kg	MTJ 38
13 mm	1 / 2"	62	14	1.27 kg	MTJ 12
16 mm	5 / 8"	62	14	1.26 kg	MTJ 58
19 mm	3 / 4"	76	17	1.50 kg	MTJ 34
22 mm	7 / 8"	76	17	1.48 kg	MTJ 78
25 mm	1"	76	17	1.45 kg	MTJ 100

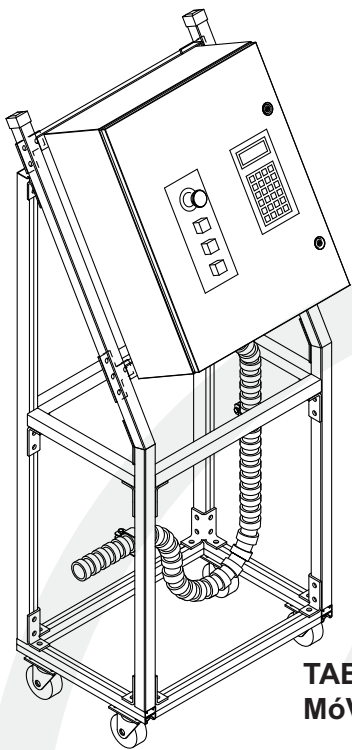

**TABLERO  
MÓVIL**

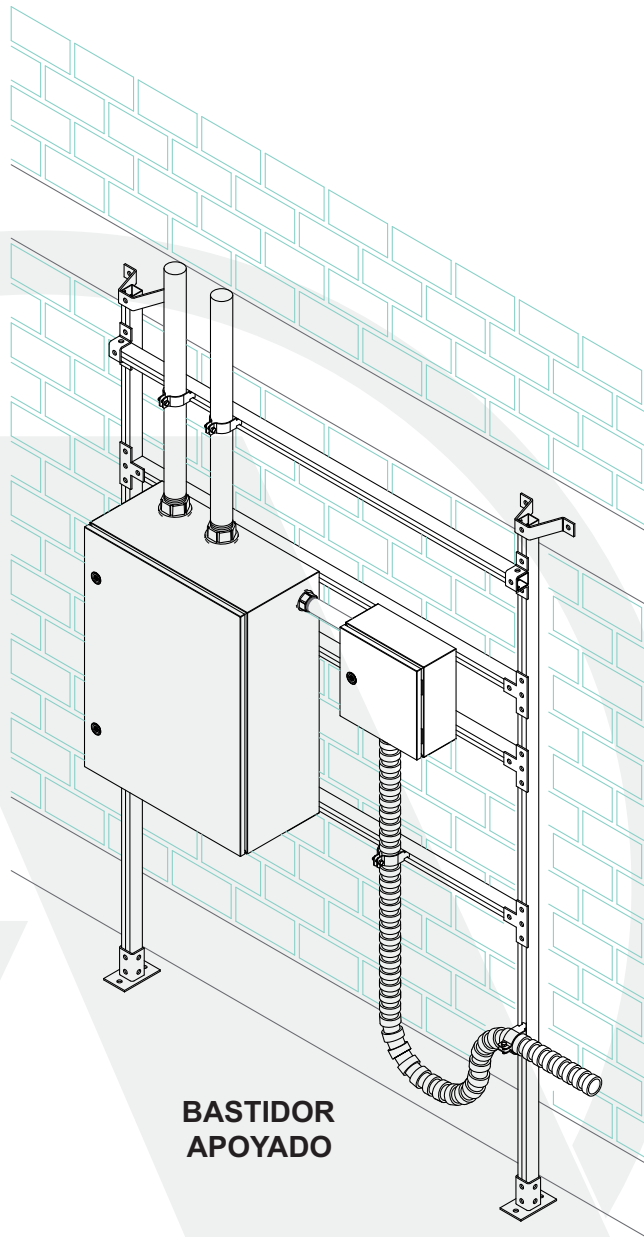

**BASTIDOR  
APOYADO**

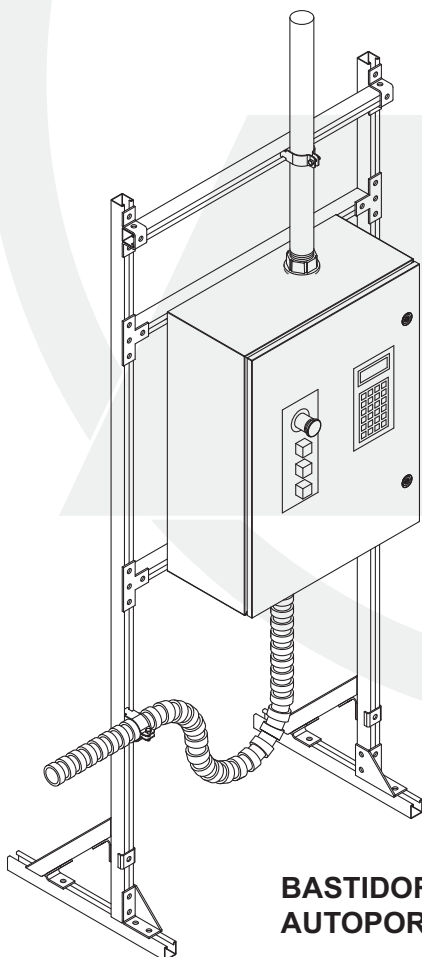

**BASTIDOR  
AUTOPORTANTE**

El sistema unicanal es ideal para el montaje de todo tipo de gabinetes eléctricos proporcionando:

- \* Gran versatilidad de montaje.
- \* Soporte de conduit o cable de entrada o salida para una instalación profesional y cumplir con norma.
- \* Mantiene separación con muros evitando corrosión y acumulación de polvo.
- \* Permite instalaciones autoportantes o móviles de gabinetes y equipos.



# ESTRUCTURAS ATORNILLADAS

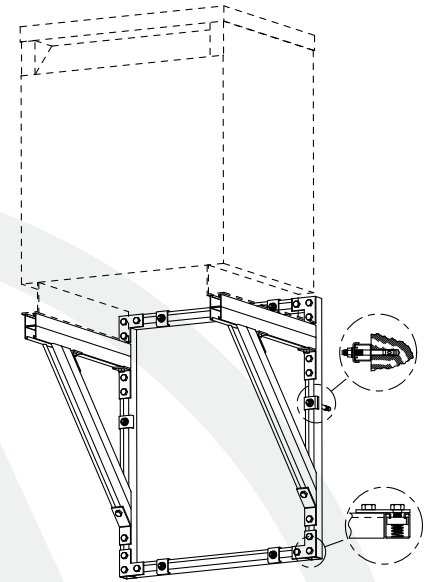
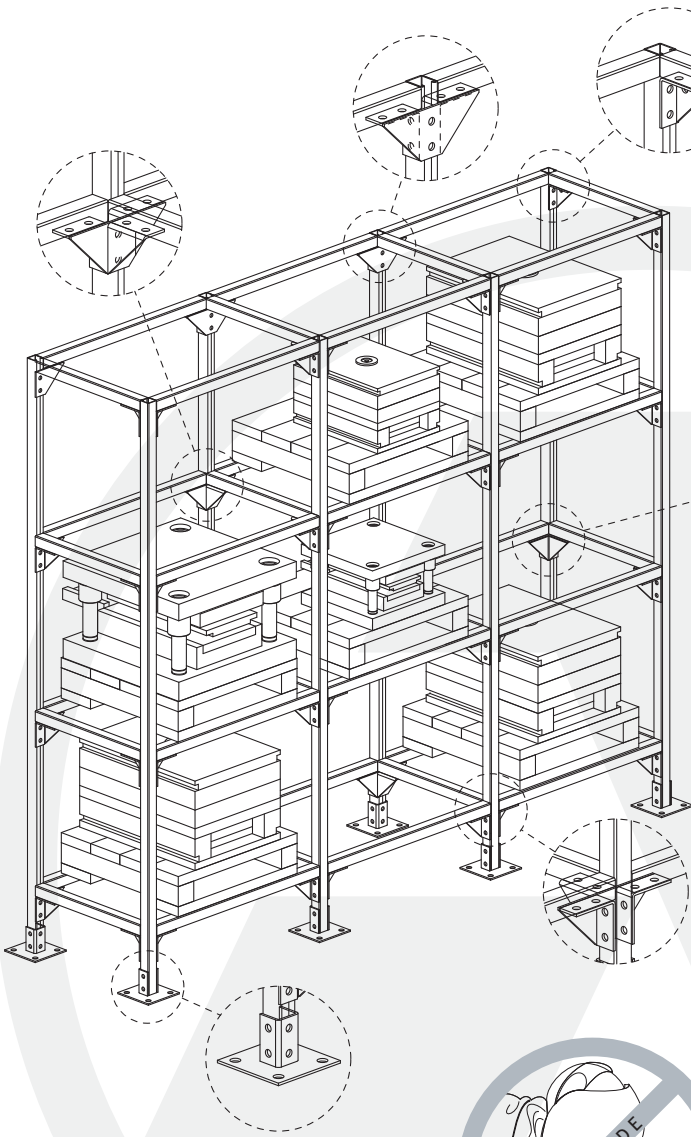

## SOPORTE EQUIPOS AUXILIARES

- \* Estructuras atornilladas auxiliares para estantes dedicados, mesas, soporte de equipos e infinidad de otras necesidades en plantas, comercios, minas e instituciones.
- \* Se fabrican rápida y limpiamente por personal de mantenimiento sin necesidad de soldadura o acabado, ni de personal especializado.

## ESTANTE USO PESADO PARA MOLDES Y TROQUELES



## MESAS DE TRABAJO O BASES PARA EQUIPOS, LIGERAS O REFORZADAS

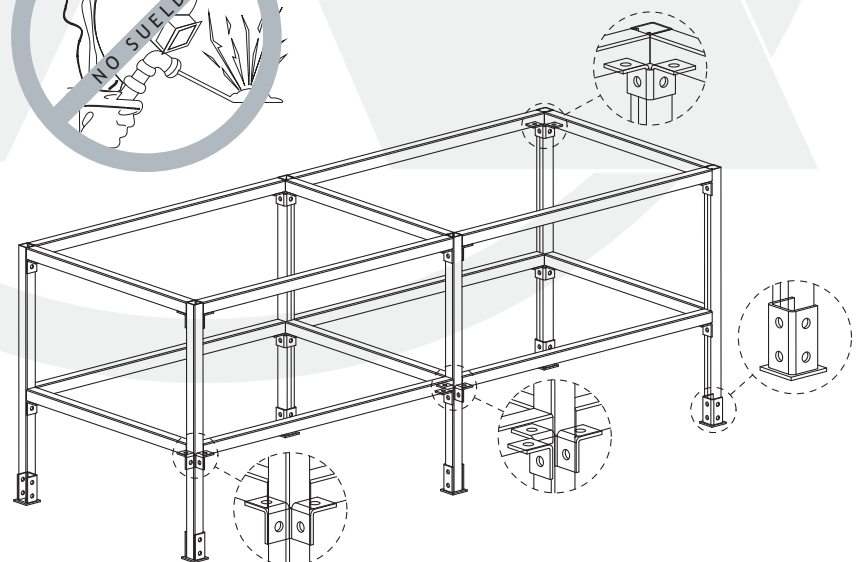



## CONEXIÓN UNICANAL

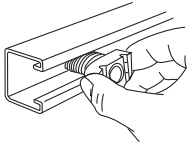

**1** Las tuercas unicanal se insertan fácilmente en cualquier punto de la ranura longitudinal. Solo presione y gire para trabar tuercas en borde 180°.

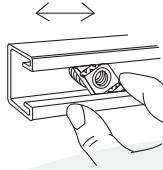

**2** El resorte mantiene las tuercas pegadas al borde 180° permitiendo simultáneamente el desplazamiento para lograr un ajuste preciso.

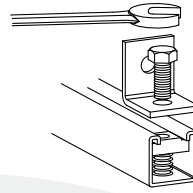

**3** Fije herraje con tornillo corto. Antes de apretar es posible mover la conexión para un alineamiento perfecto.

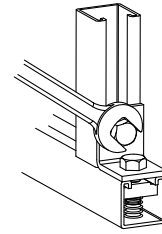

**4** Coloque y fije segundo riel para obtener una conexión rígida. Al apretar el tornillo la tuercas se encaja en el borde 180° creando una excelente conexión mecánica.

## TUERCAS UNICANAL

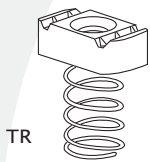

\* Acero endurecido permite a los dientes de la tuercas encajarse en el borde 180° de los rieles para lograr una óptima conexión.

\* Cuerdas estandar UNC.



Cuerda mm	Cuerda pulg	Para Unicanal	Clave Pedido
6.4 mm	1 / 4"	4 x 4	TR 14
8 mm	5 / 16"	4 x 4	TR 56
10 mm	3 / 8"	4 x 4	TR 38
13 mm	1 / 2"	4 x 4	TR 12

## TOPES UNICANAL

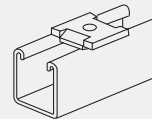

HA 03 / 04

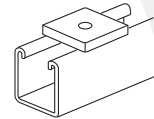

HA 01 / 02



Descripción	Para Tornillo mm	Para Tornillo pulg	Clave Pedido
Tope muescas	10 mm	3 / 8"	HA 03
Tope muescas	13 mm	1 / 2"	HA 04
Tope plano	10 mm	3 / 8"	HA 01
Tope plano	13 mm	1 / 2"	HA 02

## TOPES DE FIJACIÓN

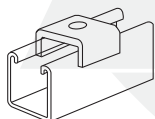

HA 06 / 07

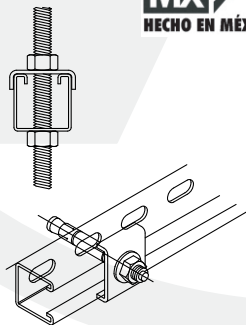

Descripción	Para Tornillo mm	Para Tornillo pulg	Clave Pedido
Tope U	10 mm	3 / 8"	HA 06
Tope U	13 mm	1 / 2"	HA 07

## REMATES UNICANAL - PVC

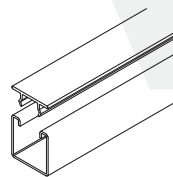

HS 01

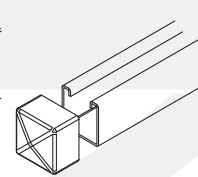

HS 02

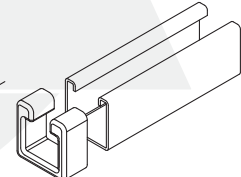

HS 03



Descripción	Clave Pedido
Tapa para Ranura UNICANAL 3 mt	HS 01
Tapón sólido para UNICANAL 4 x 4	HS 02
Borde para UNICANAL 4 x 2	HS 03
Borde para UNICANAL 4 x 4	HS 04

NO METÁLICO  
COLOR VERDE OSCURO

\* EXISTENCIAS EN SUCURSALES



# HERRAJES UNICANAL

# SERIES: A & B

- \* Los herrajes están fabricados en placa ASTM - A 635 de 4.7 mm (3 / 16") con perforaciones de 14 mm (9 / 16") para tornillos de 9.5 o 13 mm (3/8 ó 1/2") a 48 mm (1 7 / 8") entre centros y 20 mm (3 / 4") del extremo. Herrajes en placa de 6.4 mm (1 / 4") se fabrican sobre pedido.
- \* Acabado estandar es electrolgalvanizado. Pintura poliester / epoxy o galvanizado por inmersión en caliente opcionales.

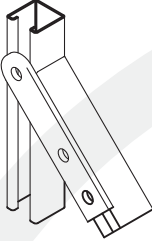
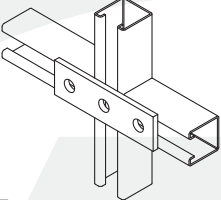
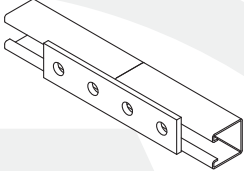
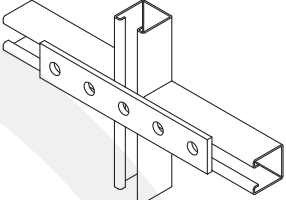
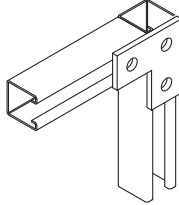
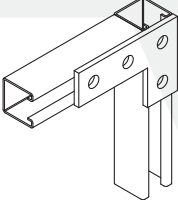
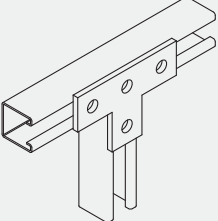
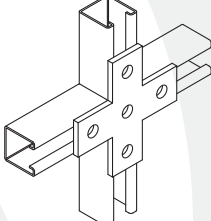
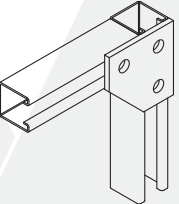
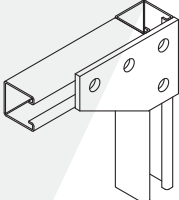
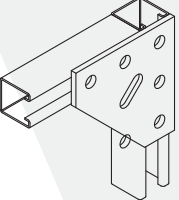
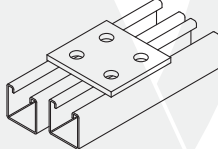
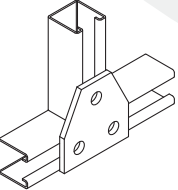
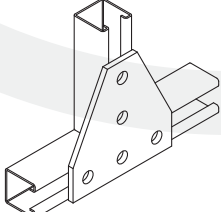
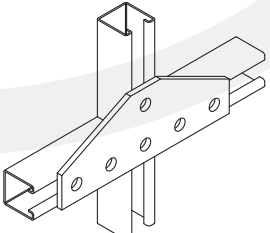
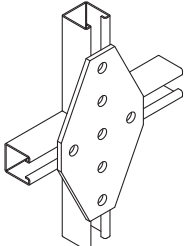
SERIE A		 *			
	HA 12	HA 09	HA 10	HA 11	
	SERIE B	 *	 *	 *	
		HB 01	HB 10	HB 04	HB 05
					
HB 02		HB 03	HB 11	HB 13	
					
HB 06	HB 07	HB 12	HB 09		

\* EXISTENCIAS EN SUCURSALES



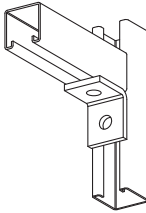
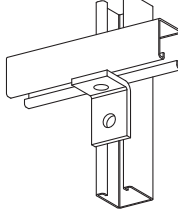
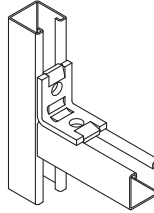
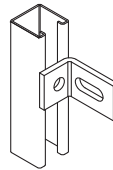
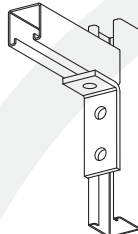
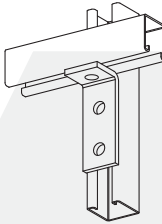
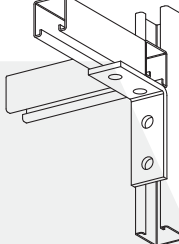
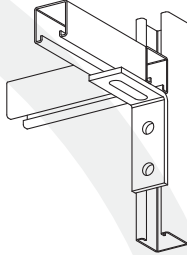
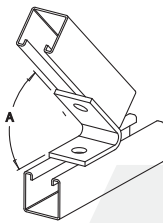
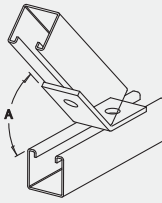
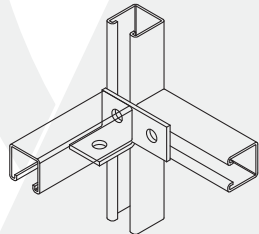
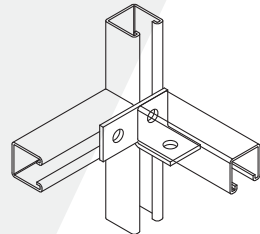
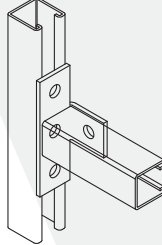
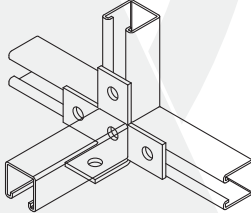
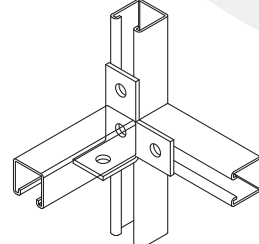
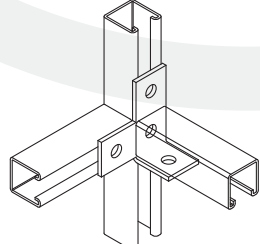
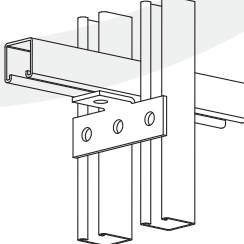

SERIE C	 * HC 01	 HC 02	 * HC 03	 HC 04																																		
	 * HC 06	 HC 05	 HC 07	 HC 09																																		
SERIE D		<table border="1"> <thead> <tr> <th>CLAVE</th> <th>A</th> </tr> </thead> <tbody> <tr> <td>HD 01</td> <td>45°</td> </tr> <tr> <td>HD 02</td> <td>60°</td> </tr> <tr> <td>HD 03</td> <td>75°</td> </tr> <tr> <td>HD 08</td> <td>37.5°</td> </tr> <tr> <td>HD 09</td> <td>52.5°</td> </tr> <tr> <td>HD 10</td> <td>67.5°</td> </tr> <tr> <td>HD 11</td> <td>82.5°</td> </tr> </tbody> </table>	CLAVE	A	HD 01	45°	HD 02	60°	HD 03	75°	HD 08	37.5°	HD 09	52.5°	HD 10	67.5°	HD 11	82.5°		<table border="1"> <thead> <tr> <th>CLAVE</th> <th>A</th> </tr> </thead> <tbody> <tr> <td>HD 04</td> <td>15°</td> </tr> <tr> <td>HD 05</td> <td>30°</td> </tr> <tr> <td>HD 06</td> <td>45°</td> </tr> <tr> <td>HD 07</td> <td>60°</td> </tr> <tr> <td>HD 12</td> <td>37.5°</td> </tr> <tr> <td>HD 13</td> <td>52.5°</td> </tr> <tr> <td>HD 14</td> <td>67.5°</td> </tr> <tr> <td>HD 15</td> <td>82.5°</td> </tr> </tbody> </table>	CLAVE	A	HD 04	15°	HD 05	30°	HD 06	45°	HD 07	60°	HD 12	37.5°	HD 13	52.5°	HD 14	67.5°	HD 15	82.5°
	CLAVE	A																																				
HD 01	45°																																					
HD 02	60°																																					
HD 03	75°																																					
HD 08	37.5°																																					
HD 09	52.5°																																					
HD 10	67.5°																																					
HD 11	82.5°																																					
CLAVE	A																																					
HD 04	15°																																					
HD 05	30°																																					
HD 06	45°																																					
HD 07	60°																																					
HD 12	37.5°																																					
HD 13	52.5°																																					
HD 14	67.5°																																					
HD 15	82.5°																																					
SERIE E	 HE 01	 HE 02	 HE 03	 HE 04																																		
	 HE 05	 HE 06	 HE 08																																			

\* EXISTENCIAS EN SUCURSALES



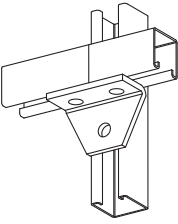
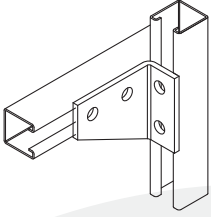
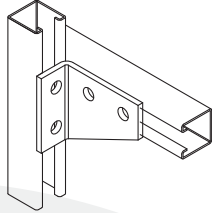
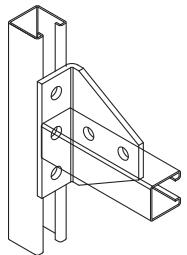
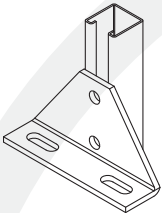
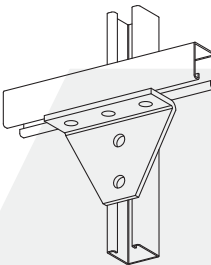
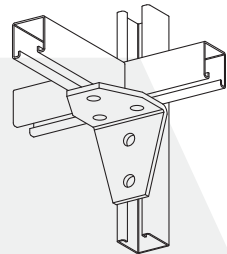
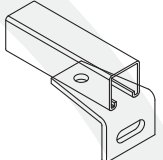
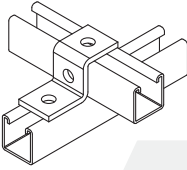
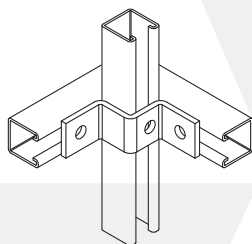
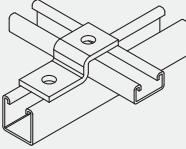
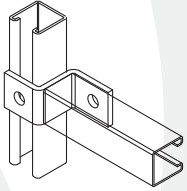

# SERIES: F, G, H, I

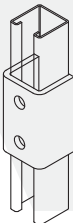
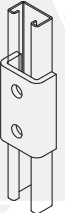
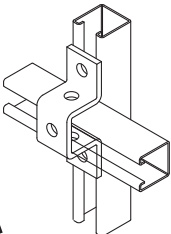
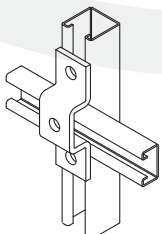
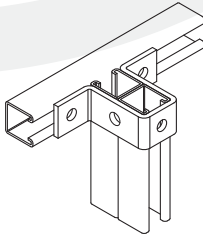
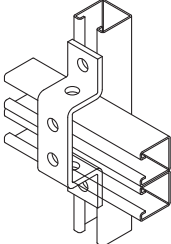
SERIE F	 HF 01	 HF 02	 HF 03	 HF 04			
	 HF 05	 HF 06	 HF 07	 HF 08			
	SERIE G	 HG 01	 HG 02	 HG 03	 HG 04		
		SERIE H	 HH 01	 HH 02	 HH 03	 HH 04	
			SERIE I	 * HI 01	 HI 02	 HI 04	 HI 05

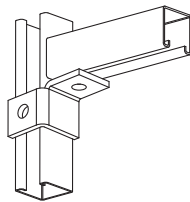
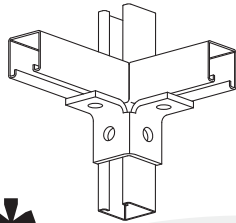
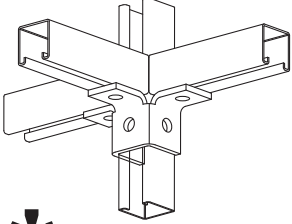
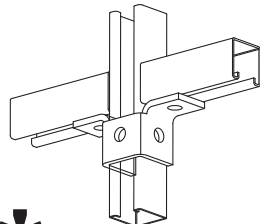
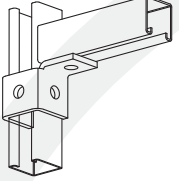
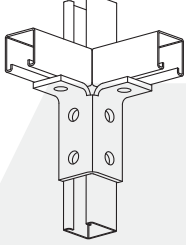
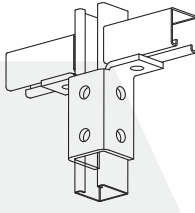
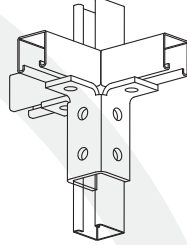
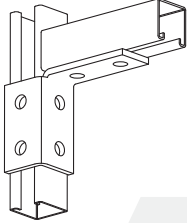
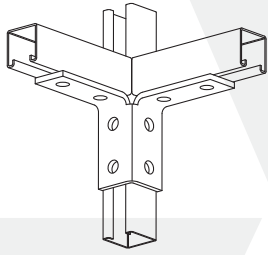
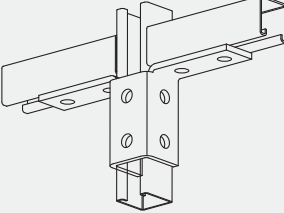
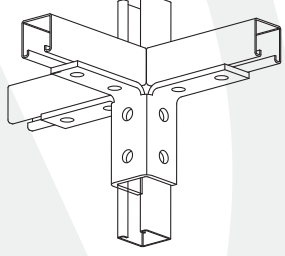
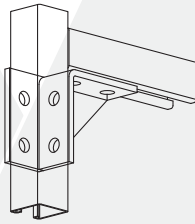
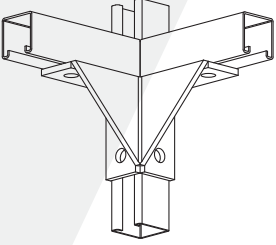
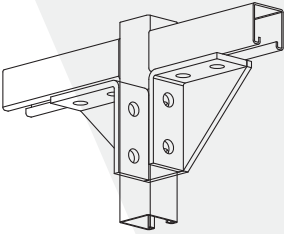
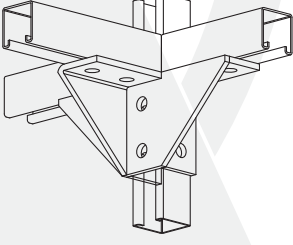
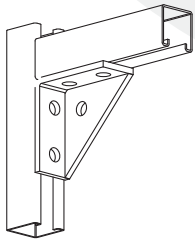

SERIE K	 HK 14      HK 15	 * HK 07	 * HK 03	 * HK 04
	 HK 01      HK 02	 HK 08	 HK 06	 HK 05
	 HK 09      HK 10	 HK 11	 HK 12	 HK 13
	 HL 02	 HL 05	 HL 04	 HL 06
SERIE L	 HL 01			

\* EXISTENCIAS EN SUCURSALES



# SERIES: N, O, R & S

SERIE N	<p>HN 01</p>	<p>HN 02</p>	<p>HN 09</p>	<p>HN 10</p>								
	<p>HN 05</p>	<p>HN 08</p>	<p>HN 03</p>	<p>HN 04</p>								
	<p>HO 01</p>	<p>HO 02</p>	<p>HO 03</p>	<p>HO 05</p>								
	<p>HO 07</p>		<p style="writing-mode: vertical-rl; transform: rotate(180deg);">SERIE Q</p>	<table border="1"> <thead> <tr> <th>CLAVE</th> <th>A</th> </tr> </thead> <tbody> <tr> <td>HQ 03</td> <td>12"</td> </tr> <tr> <td>HQ 04</td> <td>16"</td> </tr> <tr> <td>HQ 05</td> <td>18"</td> </tr> </tbody> </table>	CLAVE	A	HQ 03	12"	HQ 04	16"	HQ 05	18"
CLAVE	A											
HQ 03	12"											
HQ 04	16"											
HQ 05	18"											
SERIE R	<p>HR 01</p>	<p>HR 02</p>	<p>HR 03</p>									
		<p>PARA TUBO 32 mm (1 1/4")</p> <p>HS 07 DERECHA HS 08 IZQUIERDA</p>		<p>Se utiliza para fabricar racks para carretes de cable, manguera o conduit flexible</p>								

\* EXISTENCIAS EN SUCURSALES



### ELEMENTOS DE SECCIÓN

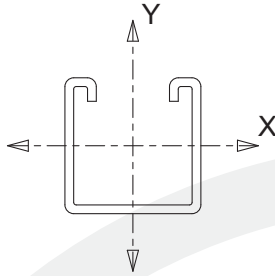

Concepto	Eje	Industrial		Hidráulico		Eléctrico	
		4 x 4	4 x 8 D*	4 x 4	4 x 8 D*	4 x 4	4 x 8 D*
Movimiento de inercia cm <sup>4</sup>	X	7.70	39.04	6.17	30.80	5.17	25.63
	Y	9.74	19.48	7.61	15.21	6.30	12.59
Módulo de sección cm <sup>3</sup>	X	3.34	9.46	2.71	7.46	2.28	6.21
	Y	4.72	9.44	3.68	7.37	3.05	6.10
Radio de giro cm	X	1.47	2.34	1.51	2.39	1.53	2.41
	Y	1.66	1.66	1.68	1.68	1.69	1.69
Área de sección cm <sup>2</sup>	-	3.61	7.21	2.66	5.32	2.13	4.26
Peso kg x mt	-	2.83	5.65	2.08	4.16	1.66	2.33

### TRAPECIOS - Soportados en ambos extremos.

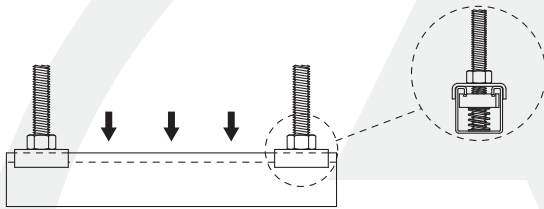

Claro Libre	Industrial		Hidráulico		Eléctrico	
	4 x 4	4 x 8 D*	4 x 4	4 x 8 D*	4 x 4	4 x 8 D*
Cargas uniformemente distribuidas en claro libre						
30 cm	1514 kg	-	1226 kg	-	1034 kg	542 kg
60 cm	757 kg	1161 kg	613 kg	778 kg	517 kg	542 kg
90 cm	504 kg	1161 kg	408 kg	778 kg	344 kg	542 kg
120 cm	337 kg	1069 kg	270 kg	778 kg	226 kg	542 kg
150 cm	215 kg	855 kg	173 kg	675 kg	145 kg	542 kg
200 cm	110 kg	558 kg	88 kg	440 kg	73 kg	366 kg

Cargas estáticas para viga simple con carga uniformemente distribuida con deflexión igual a 1 / 240 del claro libre.

### COLUMNAS - Cargas excéntricas sobre el lado abierto

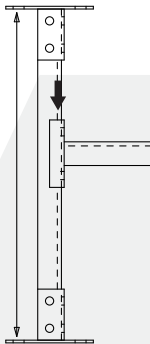

Claro Libre	Industrial		Hidráulico		Eléctrico	
	4 x 4	4 x 8 D*	4 x 4	4 x 8 D*	4 x 4	4 x 8 D*
Cargas estáticas excéntricas en lado de ranura						
30 cm	1902 kg	3114 kg	1368 kg	2218 kg	-	-
60 cm	1776 kg	3068 kg	1288 kg	2190 kg	938 kg	1597 kg
90 cm	1596 kg	2992 kg	1165 kg	2143 kg	863 kg	1569 kg
150 cm	1170 kg	2375 kg	833 kg	1788 kg	653 kg	1363 kg
200 cm	882 kg	1346 kg	596 kg	1050 kg	449 kg	838 kg
300 cm	630 kg	672 kg	419 kg	540 kg	304 kg	451 kg

Carga para viga fija con K=0.8 (Deflexión dividida entre carga expresada en libras / pie)

### COLUMNAS - Cargas al centro del perfil

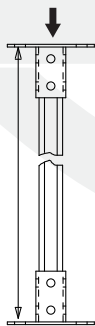

Claro Libre	Industrial		Hidráulico		Eléctrico	
	4 x 4	4 x 8 D*	4 x 4	4 x 8 D*	4 x 4	4 x 8 D*
Cargas al centro del perfil						
30 cm	4650 kg	9619 kg	2865 kg	5877 kg	1780 kg	3625 kg
60 cm	4141 kg	9414 kg	2612 kg	5779 kg	1663 kg	3581 kg
90 cm	3470 kg	9073 kg	2241 kg	5616 kg	1483 kg	3506 kg
150 cm	2098 kg	7980 kg	1338 kg	5095 kg	1001 kg	3267 kg
200 cm	1412 kg	6340 kg	844 kg	4314 kg	604 kg	2909 kg
300 cm	934 kg	3431 kg	549 kg	2679 kg	376 kg	2148 kg

El claro libre es el espacio entre soportes laterales o en los extremos

Las cargas máximas proporcionadas son el producto de cálculos basados en acero de primera de 172 MPa (25,000 PSI) con dobleces a 180° y costillas de refuerzo longitudinales en los perfiles hidráulicos y eléctricos.

Los valores son para cargas estáticas uniformemente distribuidas a lo largo del claro libre especificado.  
Para cargas vivas (vibración, impacto, golpeo) aplique factor 0.5 a los valores dados.  
Para cargas concentradas aplique factor 0.5 a los valores dados.

La información en este catálogo se proporciona como guía solamente debiendo aplicarse los factores de seguridad acostumbrados a las cargas máximas proporcionadas. En casos de aplicaciones críticas se deberán hacer pruebas en obra para determinar el comportamiento de los productos en condiciones reales.



## CARGAS DE DISEÑO CONEXIONES

FACTOR DE SEGURIDAD 2.5 / 10

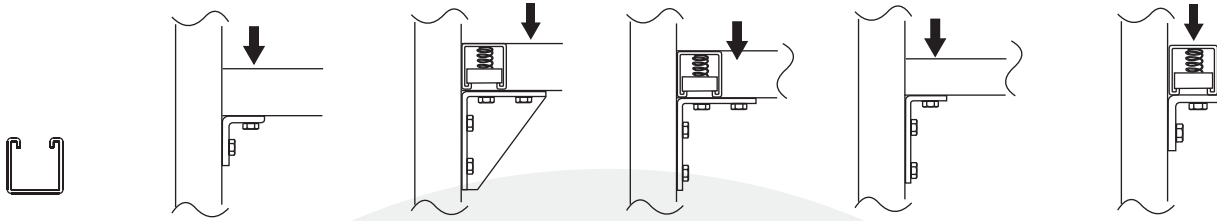

Perfil	Estática		Dinámica		Estática		Dinámica		Estática		Dinámica	
	Estática	Dinámica	Estática	Dinámica	Estática	Dinámica	Estática	Dinámica	Estática	Dinámica	Estática	Dinámica
2.7 mm C.12	6.80 kN	3.40 kN	13.61 kN	6.80 kN	9.07 kN	4.53 kN	9.07 kN	4.53 kN	2.27 kN	1.13 kN		
1.9 mm C.14	4.54 kN	2.27 kN	9.07 kN	4.53 kN	9.07 kN	4.53 kN	6.80 kN	3.40 kN	2.27 kN	1.13 kN		

## CARGAS DE DISEÑO PARA TUERCAS DE RESORTE

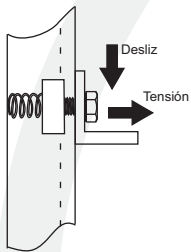

Cuerda Unc. mm pulg	En Canal 2.7 mm C.12				En Canal 1.9 mm C.14				Torque N.M.
	Tensión		Deslíz		Tensión		Deslíz		
	Estática	Dinámica	Estática	Dinámica	Estática	Dinámica	Estática	Dinámica	
6.5 1 / 4" - 20"	2.72 kN	1.36 kN	1.36 kN	0.68 kN	2.72 kN	1.36 kN	1.36 kN	0.68 kN	8
7.9 5 / 16" - 18"	3.62 kN	1.81 kN	2.26 kN	1.13 kN	3.62 kN	1.81 kN	1.81 kN	0.90 kN	15
9.5 3 / 8" - 16"	4.53 kN	2.26 kN	3.62 kN	1.81 kN	4.53 kN	2.26 kN	3.40 kN	1.70 kN	25
12.7 1 / 2" - 13"	9.07 kN	4.53 kN	6.80 kN	3.40 kN	6.35 kN	3.17 kN	4.53 kN	2.26 kN	70

## SERIE DOBLE RANURA

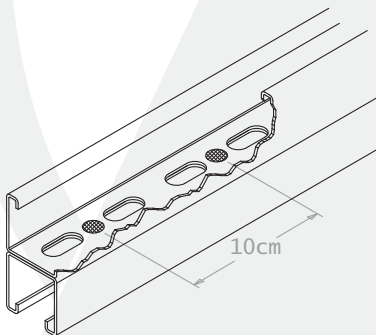

- \* Los perfiles de la serie doble ranura se fabrican con dos perfiles estandar en acabado pregalvanizado para que las partes en contacto estén protegidas.
- \* Soldadura por resistencia con intensidad y tiempo electrónicamente controlados de forma automática para garantizar la fusión de los metales. Se aplica cada 10 cm.

## PERFILES PERFORADOS

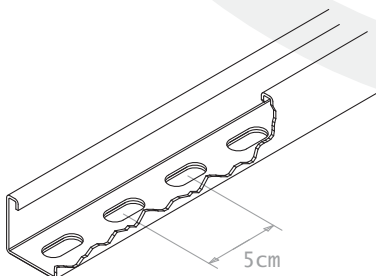

- \* Los perfiles perforados estandar tienen perforaciones ovaladas de 14 x 28 mm (9 / 16" x 1 1 / 8") a 5 cm (2") entre centros.
- \* Las perforaciones reducen los valores de carga proporcionados en aproximadamente un 5%.